

# Hydraulic self-cleaning screen filter FMA 3000

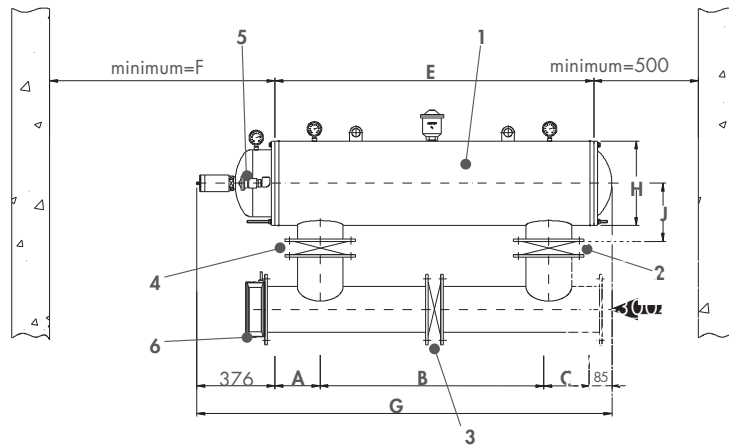

- Automatic filter Series 3000 1
- Butterfly valve inlet 2
- By-Pass valve (optional) 3
- Butterfly valve outlet 4
- Backwashing valve 2" 5
- Check valve (optional) 6



Model	In/Out Connect.	Dimensions (mm)								PVC filtering surface (cm <sup>2</sup> )	St. Steel filtering surface (cm <sup>2</sup> )	Backwashing water consumption (l)	Weight (kg.)
		A	B	C	DN	F	G	H	J				
FMA-3003	3"	166	360	185	80	690	1172	406	280	2.450	2.450	25	60
FMA-3004	4"	108	770	108	100	690	1447	406	280	4.800	4.800	49	75
FMA-3006	6"	130	1000	131	150	970	1722	406	280	7.200	7.200	110	90
FMA-3008	8"	218	1100	218	200	1240	1997	406	280	9.600	9.600	178	131
FMA-3010	10"	220	1370	221	250	1520	2272	406	280	12.000	12.000	238	164

PVC support model	PVC cartridge flow (m <sup>3</sup> /h)			
	Max. flow rate	High Quality	Medium Quality	Low Quality
FMA-3003	110	60	40	30
FMA-3004	180	80	65	50
FMA-3006	250	140	110	80
FMA-3008	400	230	180	130
FMA-3010	550	300	250	180

Stainless Steel support model	St. Steel cartridge flow rate (m <sup>3</sup> /h)			
	Max. flow rate	High Quality	Medium Quality	Low Quality
FMA-3003	110	60	50	40
FMA-3004	200	90	75	60
FMA-3006	270	150	120	90
FMA-3008	410	240	190	140
FMA-3010	580	315	260	190

Note: Values for 125 microns. Other filtration degrees available on demand