

HYDRAULIC SELF-CLEANING SCREEN FILTERS

Hydraulic self-cleaning screen filter FMA 1000

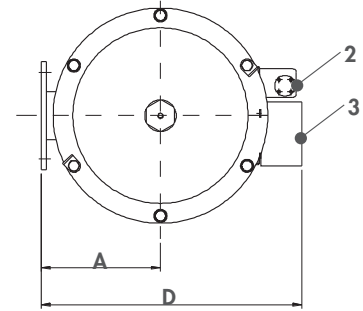
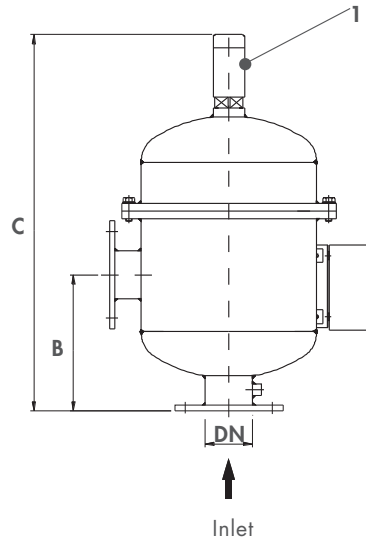

- Hydraulic Piston 1
- Solenoid 2
- Programmer 3

Model	Dimensions (mm)					Filtering surface (cm ²)		Backwashing water consumption (l)	Weight (kg.)
	A	B	C	D	DN	PVC	ST.STEEL		
FMA-1002	220	220	600	480	50	910	1000	5	35
FMA-1003	220	250	690	480	80	1600	1760	12,5	45
FMA-1004	260	320	800	570	100	2400	2650	15,5	60
FMA-1006	260	470	1075	570	150	4800	5300	53	81

PVC Model	Flow rate (m ³ /h)			
	Max. flow rate	High Quality	Medium Quality	Low Quality
FMA-1002	50	25	18	10
FMA-1003	90	50	30	20
FMA-1004	150	70	50	25
FMA-1006	280	90	70	50

ST.STEEL Model	Flow rate (m ³ /h)			
	Max. flow rate	High Quality	Medium Quality	Low Quality
FMA-1002	70	30	25	15
FMA-1003	140	60	40	20
FMA-1004	200	80	55	30
FMA-1006	350	120	100	70

Note: Values for 125 microns.
Other filtration degrees available on demand.