

MODEL	A				VOLUME			DOME VOLUME			WEIGHT	
	mm	inch	+/-		liters	U.S. gal	cubic FT	liters	U.S. gal	cubic FT	Kg	LBS
			mm	inch								
14x65	1674	65.91	6	.24	148	39.1	5.23	6.16	1.63	0.22	14.80	32.60
14x52	1340	52.76	6	.24	115	30.38	4.06	6.16	1.63	0.22	12.55	27.64
14x47	1194	47.01	6	.24	101	26.68	3.57	6.16	1.63	0.22	11.6	25.52

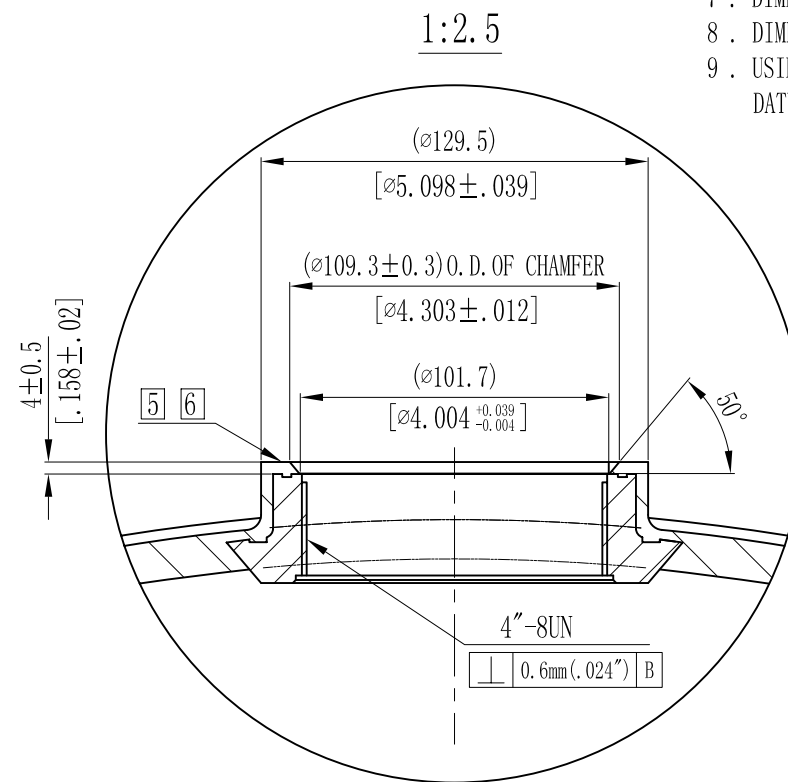
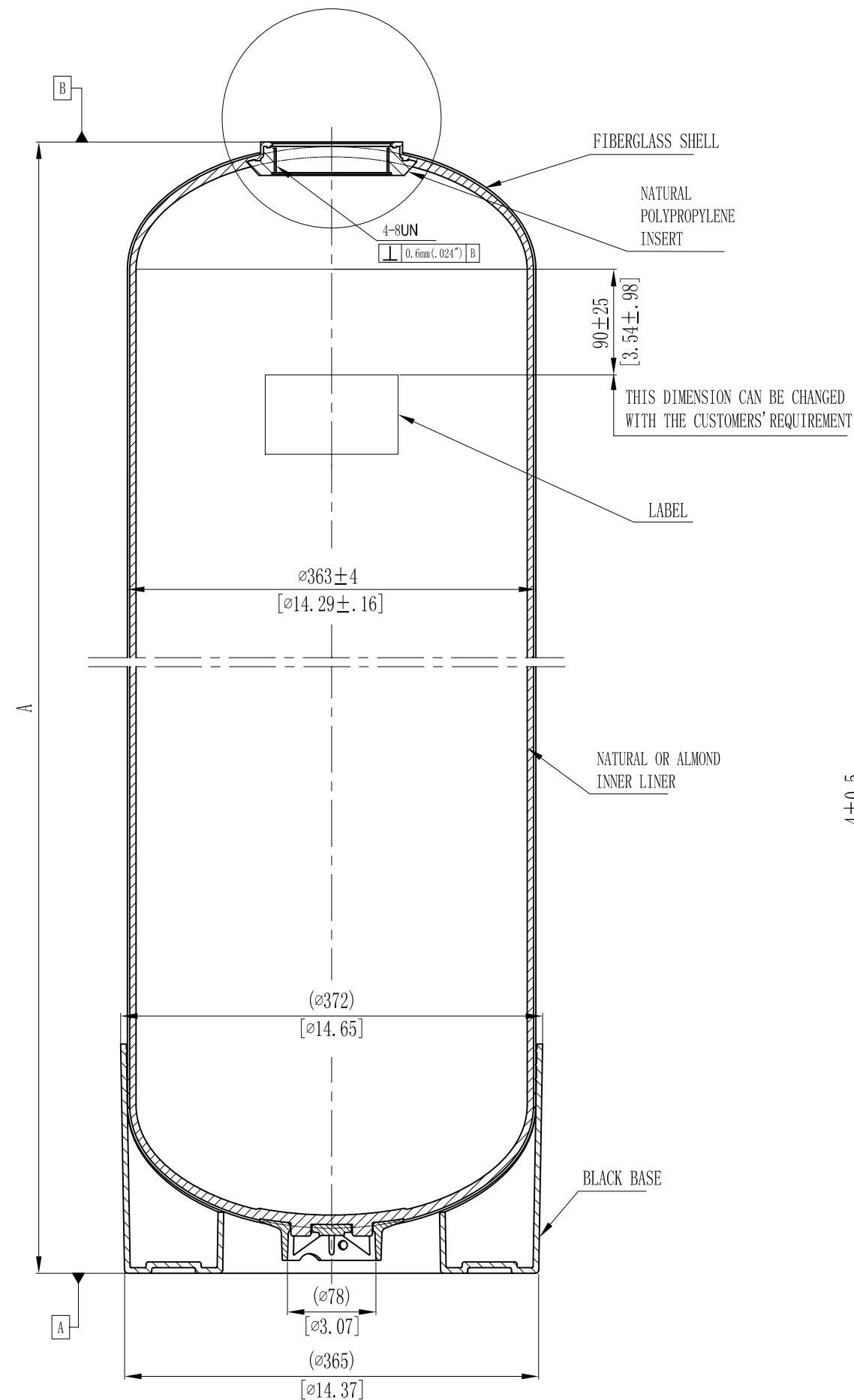

NOTES:

- 1 . TANK MUST MEET ALL APPLICABLE SPECIFICATIONS OF NSF/ANSI 044 STANDARD, LATEST REVISION.
- 2 . OPERATING SPECIFICATIONS:
  - A. MAXIMUM WORKING PRESSURE - 150 PSI (10.5BAR)
  - B. TEMPERATURE RANGE - 34-120° F (1-49°C)
  - C. MAXIMUM VACUUM - 5"Hg (127mm Hg)
- 3 . VISUAL LINER INSPECTION
  - A. NO MORE THAN 10 INTERNAL OR EXTERNAL BLEMISHES OR BURNT DEBRIS.
  - B. NO INTERNAL OR EXTERNAL BLEMISHES OR BURNT DEBRIS LARGER THAN 3×3mm.
  - C. NO INTERNAL BLEMISHES OR BURNT DEBRIS ALLOWED.
- 4 . ALL GLASS STRANDS FROM FIBERGLASS LINER TO BE BONDED AND COVERED.
- 5 . SURFACE TO BE FREE OF NICKS, SCRATCHES, RESIN AND GLASS.
- 6 . SURFACE FINISH.
- 7 . DIMENSIONS IN PARENTHESIS ARE REFERENCE ONLY.
- 8 . DIMENSIONS IN SQUARE PARENTHESIS ARE INCH UNIT.
- 9 . USING A STANDARD LEVEL WITH TANK POSITIONED ON A LEVEL SURFACE, DATUM B TO BE PARALLEL WITH DATUM A. BUBBLE OF LEVEL MUST FALL COMPLETELY WITHIN LINES WHEN MEASURED AT 90° INTERVALS.