

UV-C DISINFECTION

- RACK **DS** SERIES -

UV 400/5 DS model

IT	ENG	FR	
Portata max	Max Flow rate	Débit max	300 m³/h
N. lampade UV-C	No. of UV-C lamps	Nombre de lampes UV-C	5
Durata lampade	Life of lamps	Durée des lampes	14.000 h
Dose UV-C	UV-C Dose	UV-C Dose	> 400 J/m²

COLLETTORE	UV-CHAMBER	COLLECTEUR	
Materiale	Material	Matériel	AISI 316L
Raccordi IN-OUT	IN-OUT connections	Raccords IN-OUT	DN200 – PN10
Scarico	Drain	Décharge	1/2"
Pressione di lavoro (max.)	Working pressure (max.)	Pression de travail (max.)	9 bar
Rivestimento interno per acqua di mare	Inner coating for sea-water	Revêtement intérieur pour eau de mer	Optional
Sistema automatico di pulizia dei quarzi	Automatic Cleaning System	Système automatique de nettoyage	Optional

QUADRO ELETTRICO	ELECTRICAL PANEL	PANNEAU ELECTRIQUE	
Alimentazione elettrica	Electrical alimentation	Alimentation électrique	230 V – 50/60 Hz
Consumo elettrico	Electrical absorption	Absorption électrique	2180 Wh
Grado protezione	Protection degree	Degré de protection	IP 54
Cavo alimentazione Cavi collegamento lampade	Feeding cable Lamps connection cables	Câble d'alimentation Câble de connexion lampe	250 cm 250 cm
Controllo funzionamento lampade	Control of lamps working	Contrôle fonctionnement lampes	●
Contaore e Contaore resettabile con avviso fine vita lampada	Hour-meter and Resettable count down hour-meter with alarm for end lamp life	Compte-heures/compte-heures avec alarme de fin vie la lampe	●
Contatto pulito NA/NC Uscita NA/NC 230V-5A max	Free contact NO/NC 230V NA/NC Outlet – 5A max	Contact libre NO/NC Sortie NA/NC 230V-5A max	●
Accensione Spegnimento da Remoto	Remote ON/OFF	Allumage éteignement a'distance	●
Controllo Temperatura Quadro	Electrical Panel Temperature Control	Contrôle Température Panneau	●
Possibilità di lavoro intermittente	ON/OFF timer	Possibilité de Travail Intermittent	●
Monitoraggio irraggiamento/temperatura acqua	Control of water temperature-irradiation	Contrôle rayonnement/température	●
Spegnimento per alta temperatura collettore e quadro	Shutdown for high temperature UV chamber or electrical panel	Eteignement pour haute température collecteur/ panneau électrique	●

Optionals	Spegnimento per allagamento	Shut OFF for flooding	Eteignement pour noyage
	Possibilità di comunicazione ad un flussimetro esterno	Possible communication with an external flow meter	Possibilité de communication avec un fluxmètre extérieur
	Memorizzazione eventi (dati scaricabili con software dedicato)	Datalog (data downloadable with the appropriate software)	Mémorisation événements (données déchargeables avec software)
	Mem. irraggiamento/temperatura (scaricabile con software dedicato)	Datalog Irr./Temp. (downloadable with appropriate software)	Mém. rayonnement/température (déchargeables avec software)
	Calcolo della Dose UV	Dose Calculation	Calcul de la dose UV
	Uscita 4 – 20 mA	4-20 mA Outlet	Sortie 4 – 20 mA

(*) Dose UV calcolata con/Dose calculated with/Dosage UV calculé avec: T: 97% (1 cm), T=20°C, 14000 h

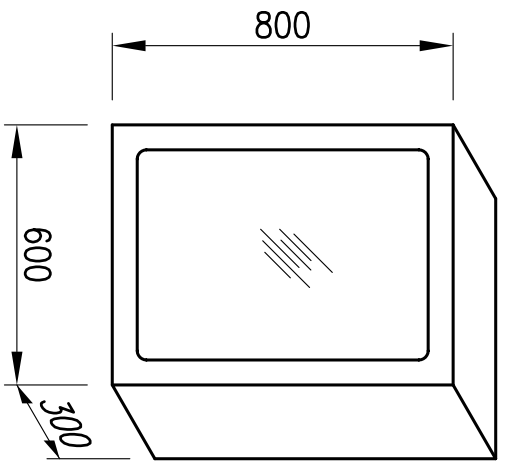
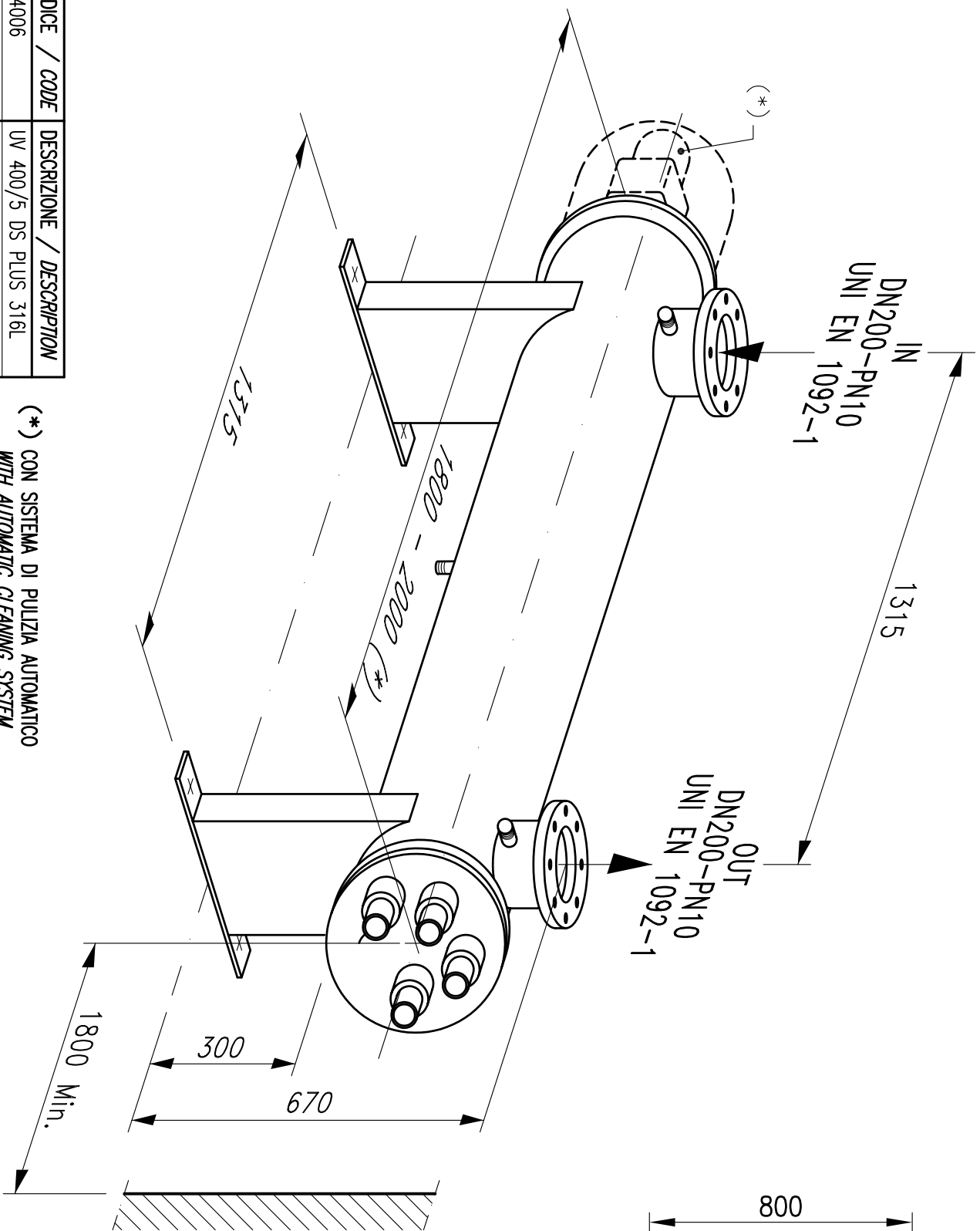

**QUADRO ELETTRICO
ELECTRICAL PANEL**

CODICE / CODE	DESCRIZIONE / DESCRIPTION
DS4006	UV 400/5 DS PLUS 316L

(*) CON SISTEMA DI PULIZIA AUTOMATICO
WITH AUTOMATIC CLEANING SYSTEM

NOTA:
- LE DIMENSIONI DI INGOMBRO INDICATE SONO SUSCETTIBILI DI MINIME VARIAZIONI DOVUTE ALLE TOLLERANZE COSTRUTTIVE E DI ASSEMBLAGGIO DEI COMPONENTI MECCANICI IMPIEGATI

NOTE:
- THESE OVERALL DIMENSIONS CAN CHANGE A LITTLE BECAUSE OF THE CONSTRUCTIVE TOLERANCES AND THE ASSEMBLING OF MECHANICAL COMPONENTS YOU USED.

NOTE:
- CES TOTALES DIMENSIONS PEUVENT SUBIR DES MOINDRES MODIFICATIONS POUR LES CONSTRUCTIVES TOLERANCES ET L'ASSEMBLAGE DES MECANIKUES ELEMENTS UTILISES.